

## Emergency LED Downlights - White

TRADELIKE

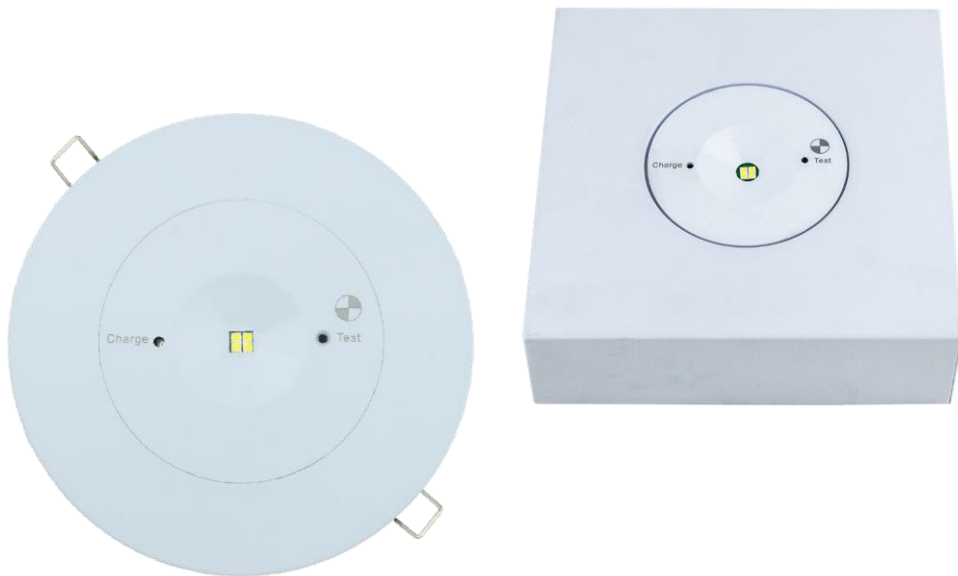

### FEATURES

- Low power consumption
  - 50,000hr LED - energy efficient, long life
  - Quick fit bracket for fast ceiling and wall mount
  - Easy testing and maintenance
- Non-maintained
- 3 hour discharge
  - 3 year warranty
  - 1.2m flex and plug (recessed only - surface mounted hard-wired)
  - Designed and manufactured to AS/NZS2293.3

### DIMENSIONS

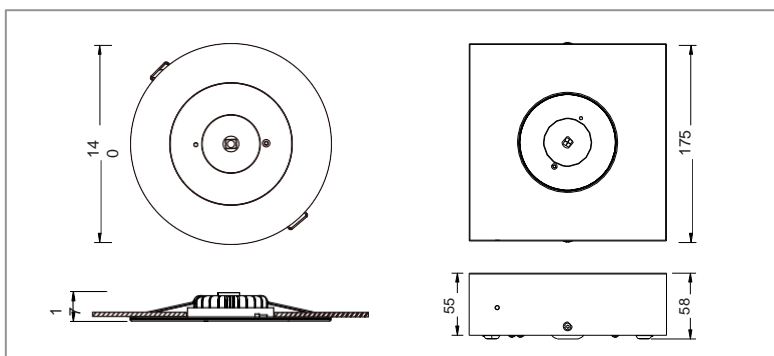

### SPECIFICATIONS

	Recessed	Surface Mount
Antec Order Code	EL-DOWN-REC	EL-DOWN-SM
Input Voltage	240v	
Wattage	3w	
Construction	Polycarbonate body with aluminium heat sink	
Mounting	Recessed and surface mounted	
Operating Mode	Maintained	
Testing System	Manual	
Battery	Lithium 2200mAh 3 hour discharge	
AS2293 Classification	D40	
Applicable Standard	AS/NZS2293.3	
Operating Temp	1°C to 40°C	
Dimensions		